

Density Drill

Some objects tend to be “heavy,” while other objects seem “light.” But unless you are comparing the same volume of each object, these descriptions have little value. And that is where the concept of density comes in. Density refers to how much mass an object has in a particular volume. Scientifically, density is described as mass per unit volume, or $\text{density} = \text{mass}/\text{volume}$. Because mass is measured in grams, and volume is measured in cubic centimeters, the unit for density is grams per cubic centimeter.

If the mass and volume of an object are known, its density can be determined by dividing the volume value into the mass value. Similarly, if the density and mass are known, the object’s volume can be determined by dividing the density value into the mass value. Finally, if an object’s density and volume are known, its mass can be found by multiplying these two values. You can see how density, mass, and volume are related by doing this activity. In each situation, you are given enough information to determine the unknown value in the formula $D = M/V$.

- A. 1. The mass of object A, as shown by the positions of the balance riders, is _____ g.
2. The volume of object A, as indicated by the given dimensions, is _____ cm^3 .

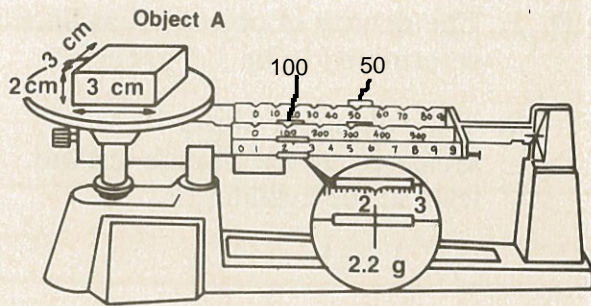

3. Using the formula $D = \frac{M}{V}$, calculate the density of object A.
- A. _____ g/cm^3
4. If object A is cut into two equal parts, what is the density of one half of A? _____ g/cm^3 Of the other half? _____ g/cm^3 . How does the density of object A compare to the density of half of object A? _____

- B. 1. The mass of object B has been determined to be 125 gs.
2. The volume of object B, as indicated by the change in fluid level in the cylinder, is _____.

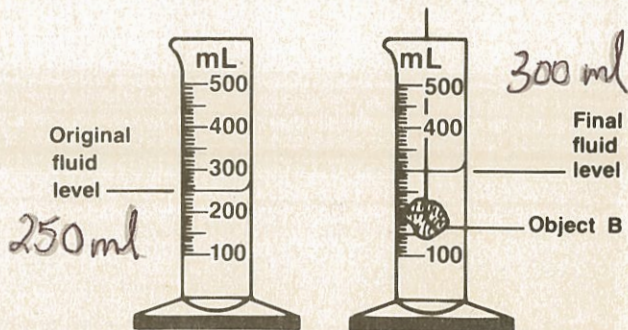

3. Using the formula $D = \frac{M}{V}$, calculate the density of object B.

_____ g/cm³

C. 1. Object C is a perfect cube. The mass of object C, as shown by the position of the balance riders, is

_____ g.

2. The density of object C has been determined to be 5.5 g/cm³.

3. Using the formula $V = \frac{M}{D}$,

calculate the volume of

object C. _____ cm³

4. Since object C is a perfect cube, determine the length of each side of that cube.
Hint: The formula for the volume of a cube is $V = L \times W \times H$. Length of any

side of cube C = _____ cm.

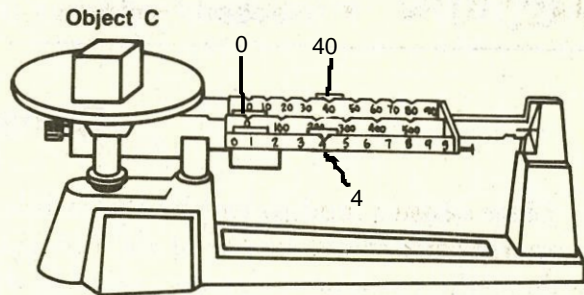

D. 1. The density of object D has been determined to be 1.4 g/cm³.

2. The volume of object D, as indicated by the change in fluid level in the cylinder, is

_____ cm³.

3. Using the formula $M = D \times V$, calculate the mass of object D.

_____ g

